

# Transport Mode

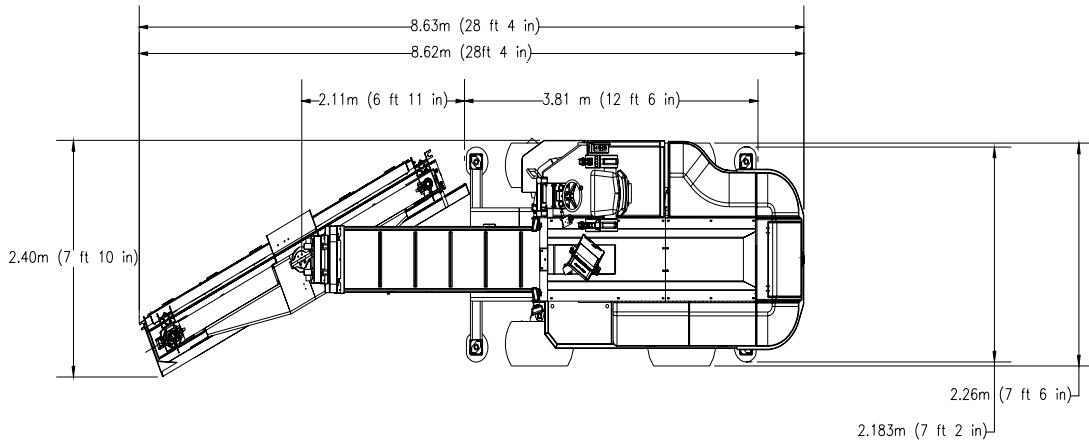

# Drive Mode

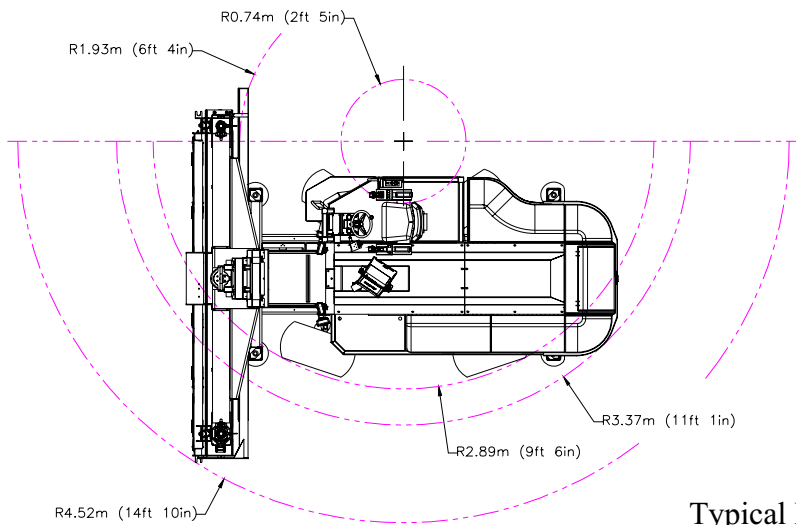
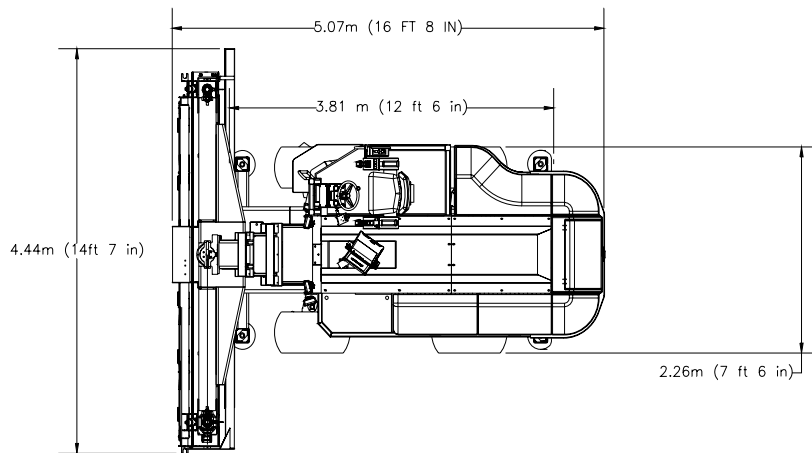

Typical Minimum Turn Radii

SXP Laser Screed w/12.5' Head  
 General Dimensions  
 Driving and Transport Mode.



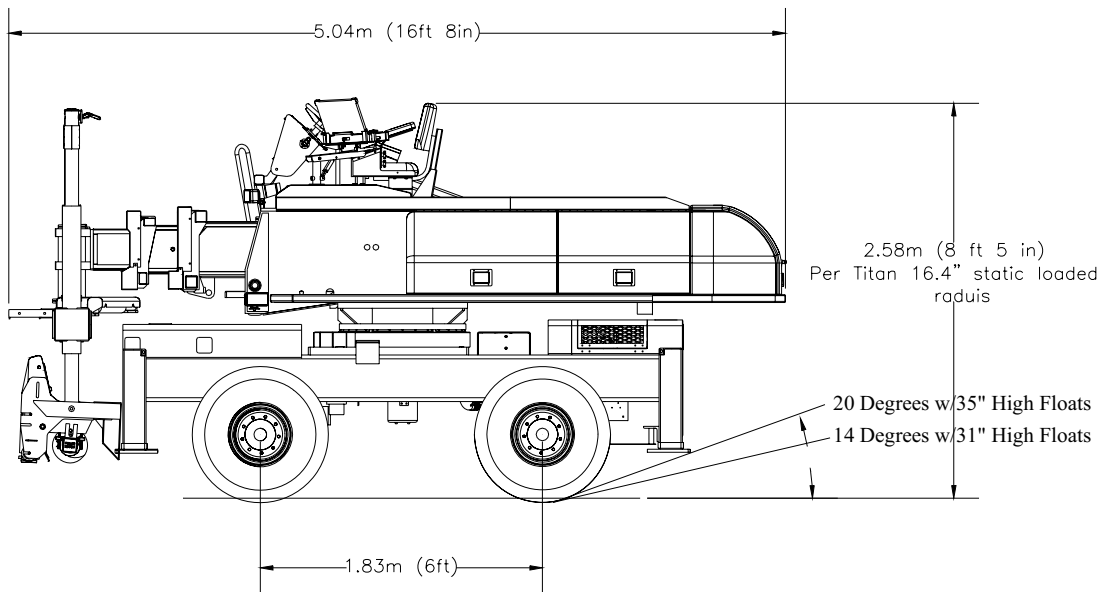
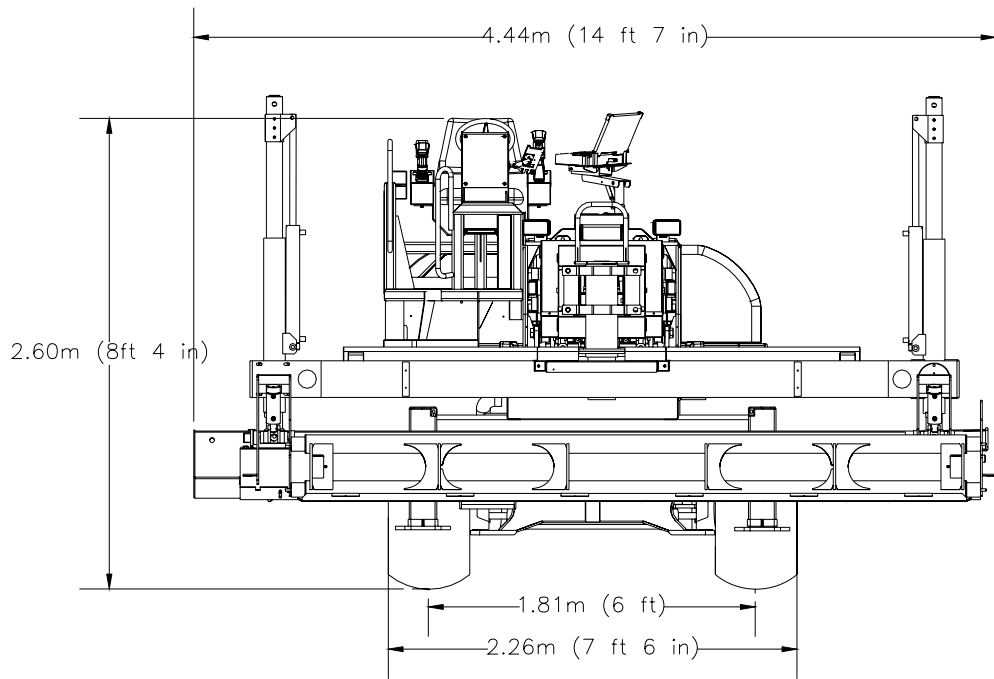

**SXP LASER SCREED w/12.5' Head  
GENERAL DIMENSIONS  
DRIVING AND TRANSPORT MODE**



Total SXP Weight 17,200 Lbs (7800 kg)

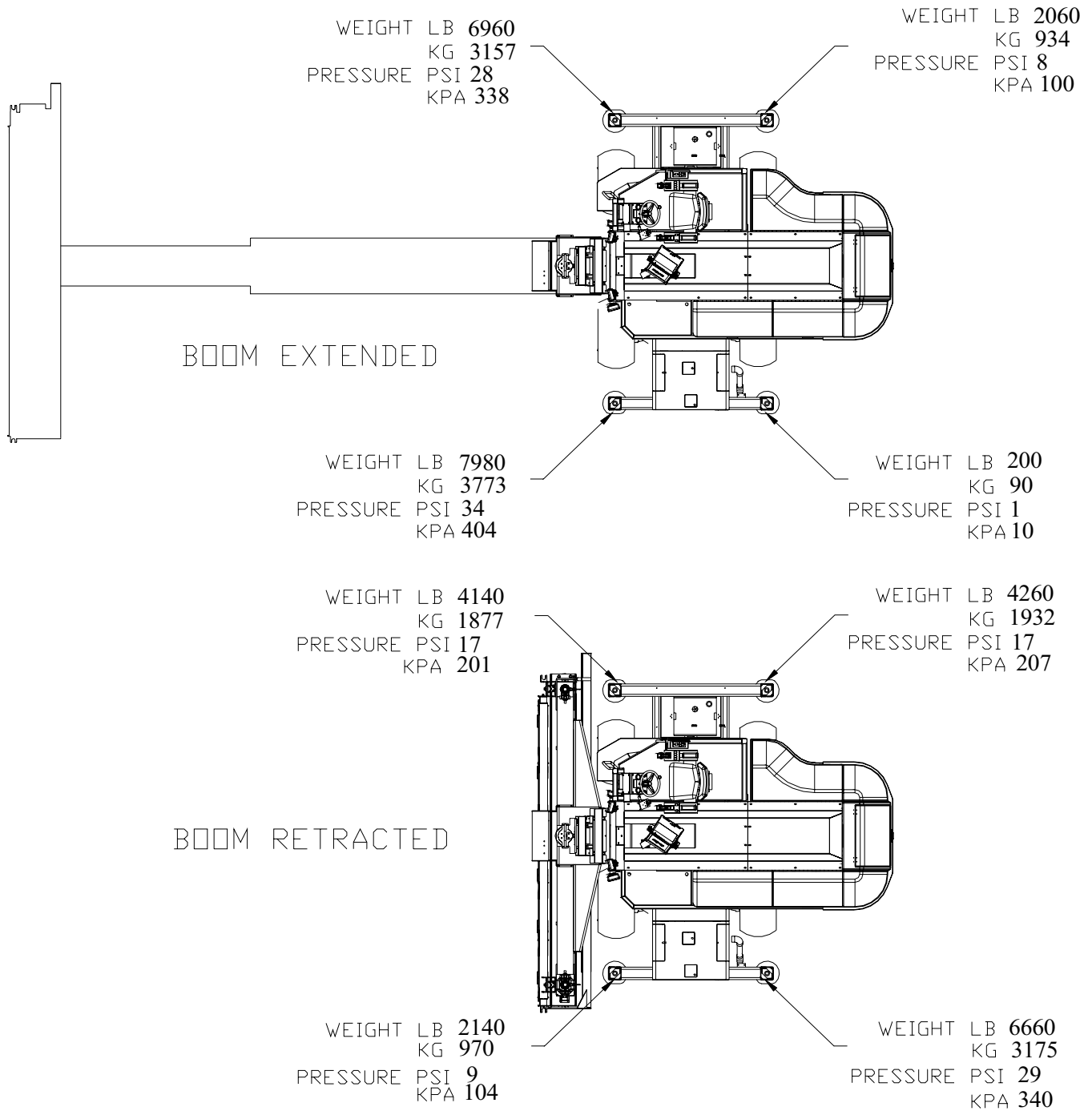

NOTE: SOME WEIGHTS AND PRESSURES MAY BE INFLUENCED BY 3-POINT CONTACT  
 SCALE ACCURACY: MAXIMUM 2% ERROR

SXP LASER SCREED  
 WEIGHT DISTRIBUTION  
 SCREEDING POSITION  
 STABILIZERS EXTENDED-STANDARD PADS



Total SXP Weight 17,200 Lbs (7800 kg)

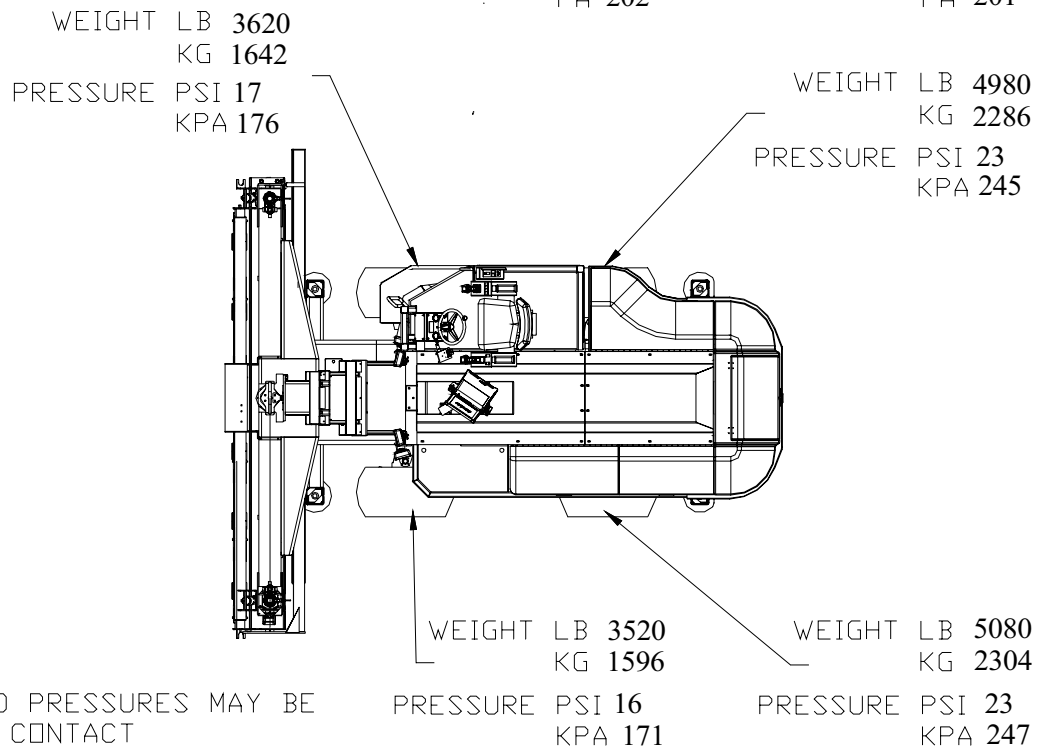
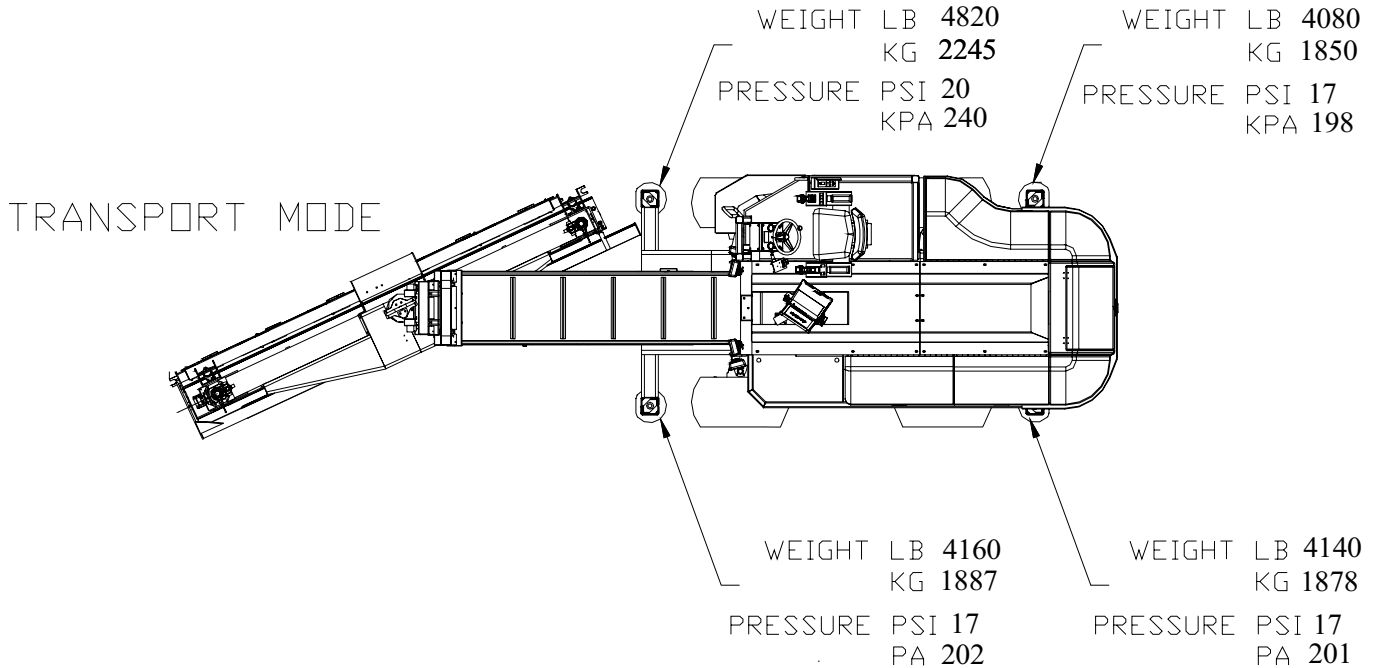

NOTE: SOME WEIGHTS AND PRESSURES MAY BE INFLUENCED BY 3-POINT CONTACT  
SCALE ACCURACY: MAXIMUM 2% ERROR

SXP LASER SCREED  
WEIGHT DISTRIBUTION  
TRANSPORT POSITION/STABILIZERS EXTENDED-STANDARD PADS  
DRIVING POSITION/STABILIZERS RETRACTED



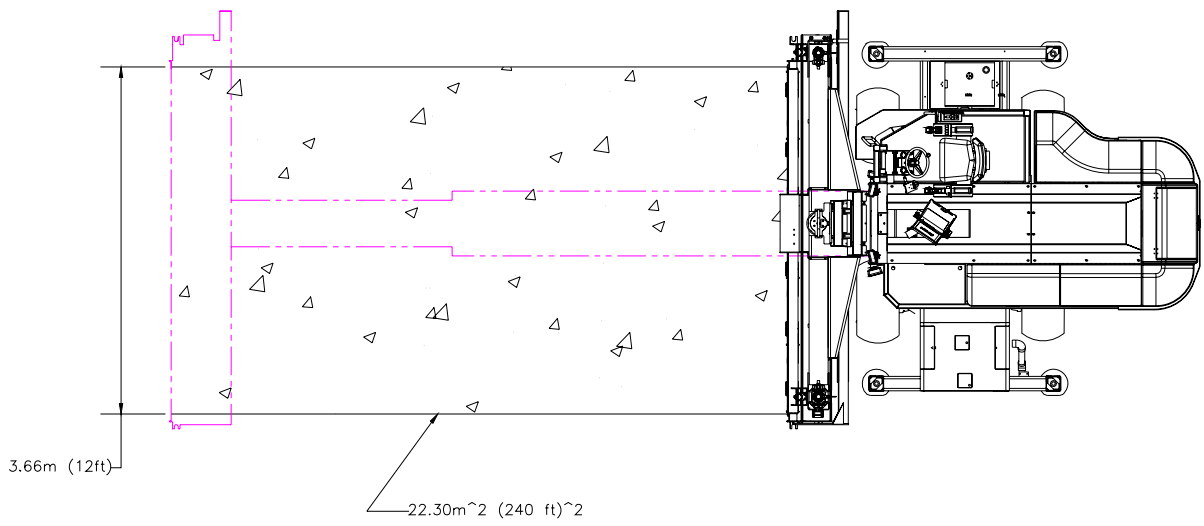
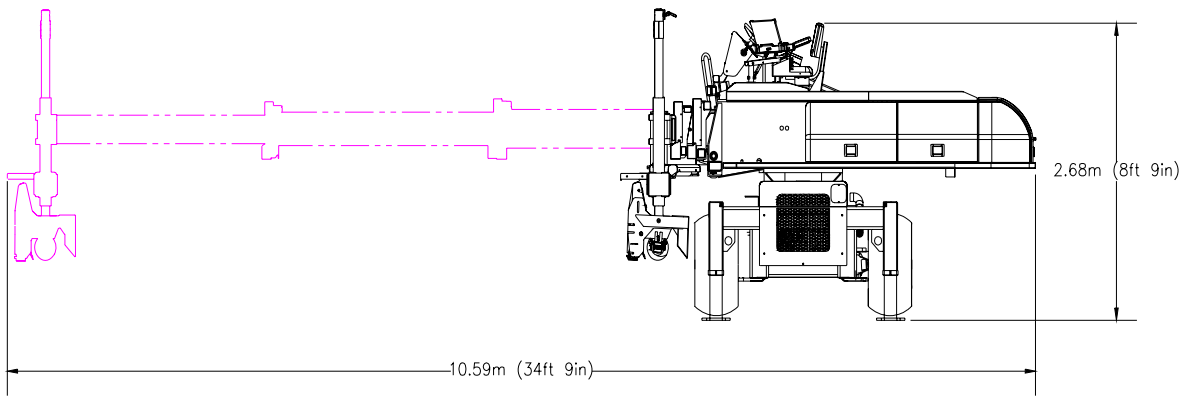

# SXP LOADING & TRANSPORTING INSTRUCTIONS

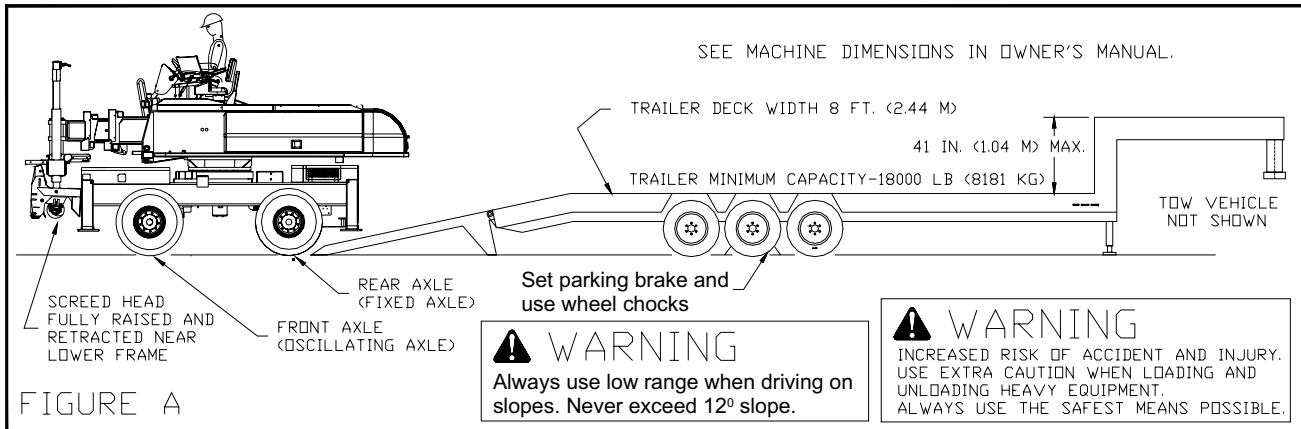

FIGURE A

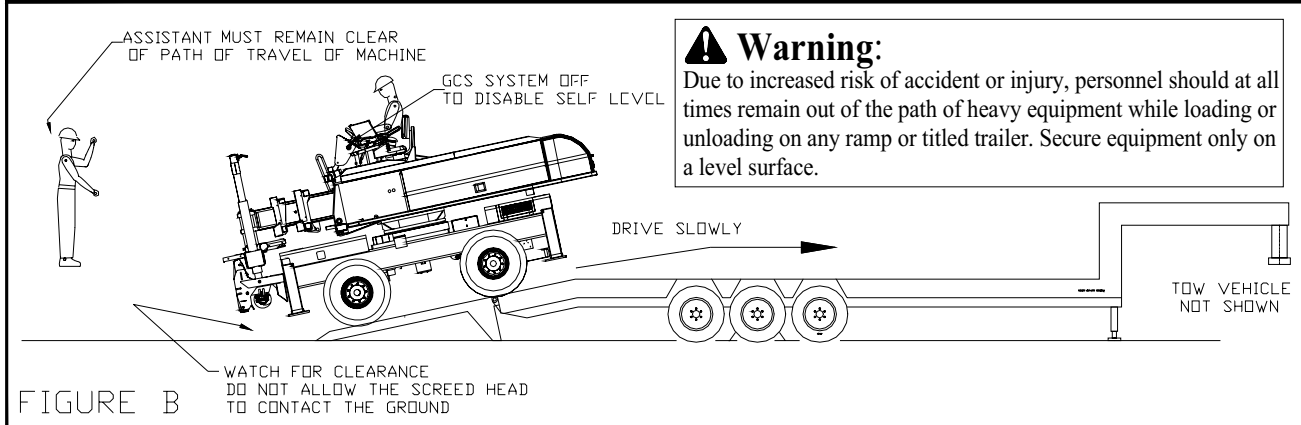

FIGURE B

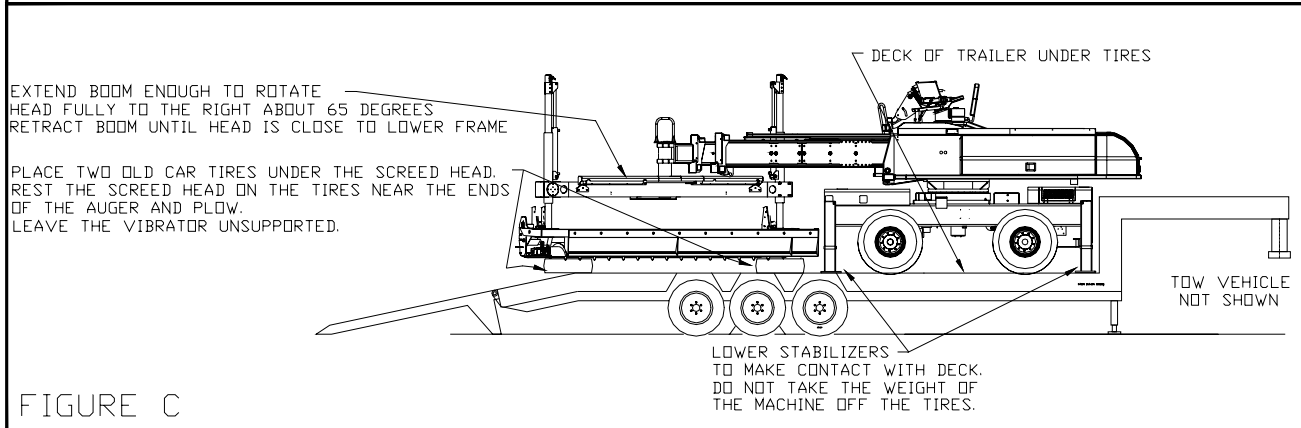

FIGURE C

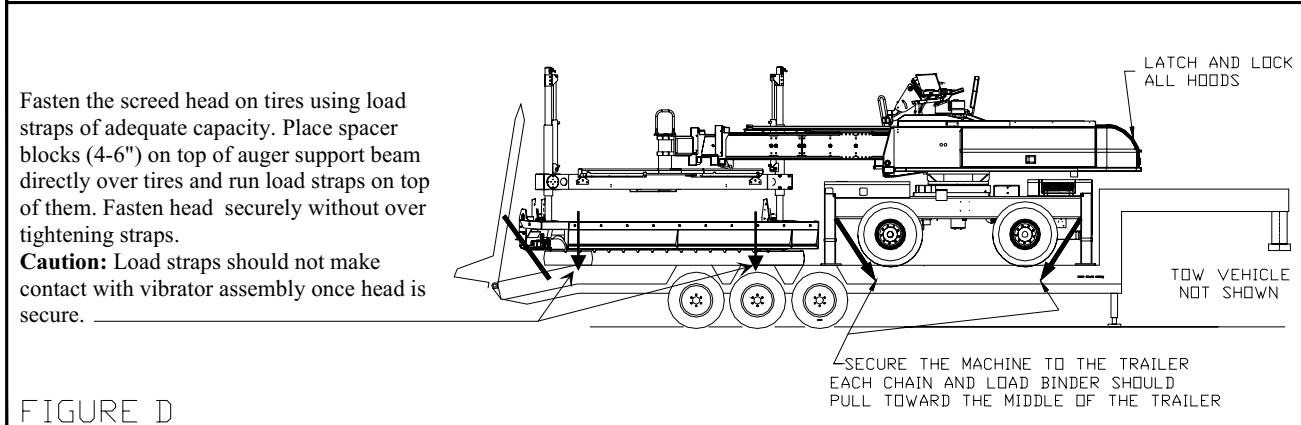

FIGURE D

REFER TO "SXP LASER SCREED OPERATOR'S MANUAL" FOR ADDITIONAL INFORMATION

